

# SKIOLD BUCKET ELEVATORS

D133-200-260-390

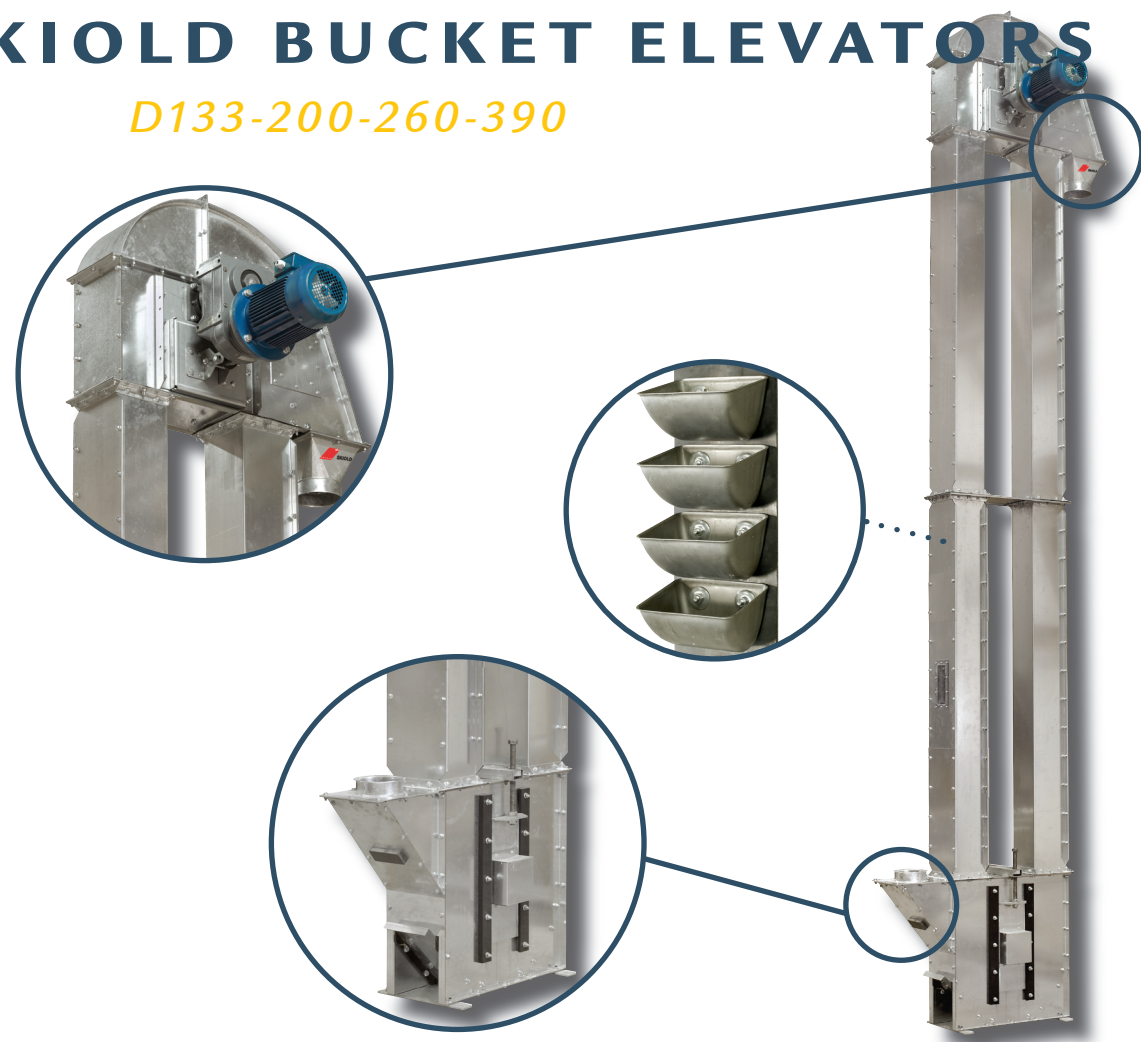

# SKIOLD BUCKET ELEVATORS

D133-200-260-390

## BUCKET ELEVATORS

The SKIOLD bucket elevators, type D, are designed for vertical conveying of grain, granulates and meal products – say ordinary small-grained crops and feed pellets with a maximum diameter of 16 mm and a maximum moisture content of 25% - yielding a capacity of up to 200 t/h in a maximum height of 40 m.

## MODULAR CONSTRUCTION

The construction of the elevators is based on modular sections comprising elevator foot, elevator head and extension sections equally equipped with bolt flanges for easy mounting. The extension sections come in lengths of 1.45, 1.95 and 2.45 m. The modular sections system, also comprising the accessory programme, is easily assembled and flexible securing the optimum design and solution for your specific task.

## INDUSTRIAL DESIGN

The SKIOLD bucket elevators are made in solid industrial design ensuring reliable operation for many hours a day. The elevator legging (trunking) is made from 1.5-2.0 mm

plate, head and base from 2.0-4.0 mm plate. All parts are as a minimum made from galvanized plate and a large number of key components have been hot dip galvanized.

## SHAFT MOUNTED GEARED MOTORS

The SKIOLD bucket elevators come with shaft mounted helical geared motors securing a minimum of maintenance. The gear motors can be either right or left fitted, again securing a high degree of flexibility.

## ACCESSORY

In addition, a profound accessory programme is available comprising:

- Misalignment control
- Dust aspiration
- Explosion relief
- Fittings for ladder
- Rain cap for motor (outdoor installation)
- Inlet regulations
- Various in- & outlet dimensions

SKIOLD MAKES THE DIFFERENCE!



- Capacity up to 200 tons/hour
- Vertical conveying of grain, granulates and meal
- Solid, galvanized construction
- Shaft mounted helical geared motor
- ATEX zone 22 approved

	A	B	C	D	E	F	F1	G	I	J	L
D133	133	133	267	605	633	2000	-	193	790	130	130
D200 I	200	200	295	750	735	2000	2500	260	1045	194	194
D200 II	200	200	295	750	735	2000	2500	260	1045	194	194
D260	260	228	380	1020	875	2000	2500	325	1370	310	256
D390	390	260	480	1160	1110	2000	2500	461	1550	300	386

Inlet and outlet can be supplied in the dimensions Ø150, 200, 250, 300 and Q16, 20, 24, 30

	Max. m <sup>3</sup> /hour	Bucket type	Buckets per meter	Belt width, mm	Motor kW	Max. height at max. capacity
D133	14 / 21	SPS80-80	9 / 13	100	1,1-2,2	35
D200 I	21 / 26 / 34	SPS100-90	8,5 / 10,5 / 14	120	2,2-4,0	40
D200 II	42 / 52 / 68	SPS 140-120	6,5 / 8 / 10,5	160	2,2-7,5	38
D260	94 / 120 / 145	SPS 200-150	5,5 / 7 / 8,5	215	5,5-15	36
D390	166 / 222 / 259	SPS 300-165A	4,5 / 6 / 7	330	11-30	41

Capacities in m<sup>3</sup>, grain. Capacity will vary for meal products. See detailed data sheet.

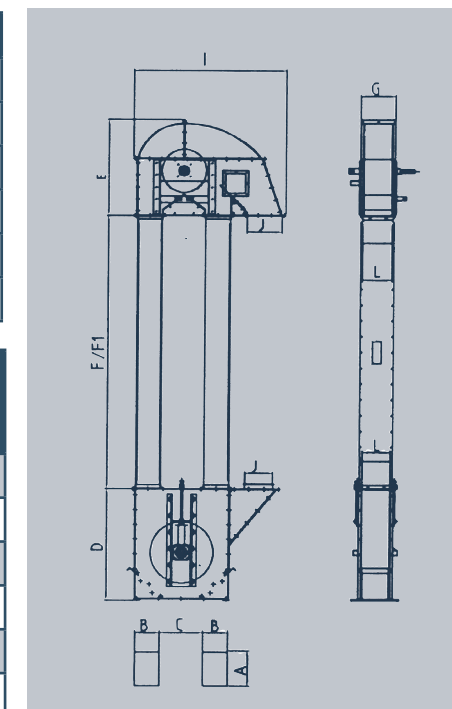

SKIOLD Reklame & Marketing - CB-2006.05.01 - All Rights Reserved.



SKIOLD A/S  
Kjeldgaardsvej · DK-9300 Sæby ·  
Tel: +45 99 89 88 87 · Fax: +45 99 89 88 77  
www.skiold.com · skiold@skiold.com



# SKIOLD BUCKET ELEVATORS

D133-200-260-390

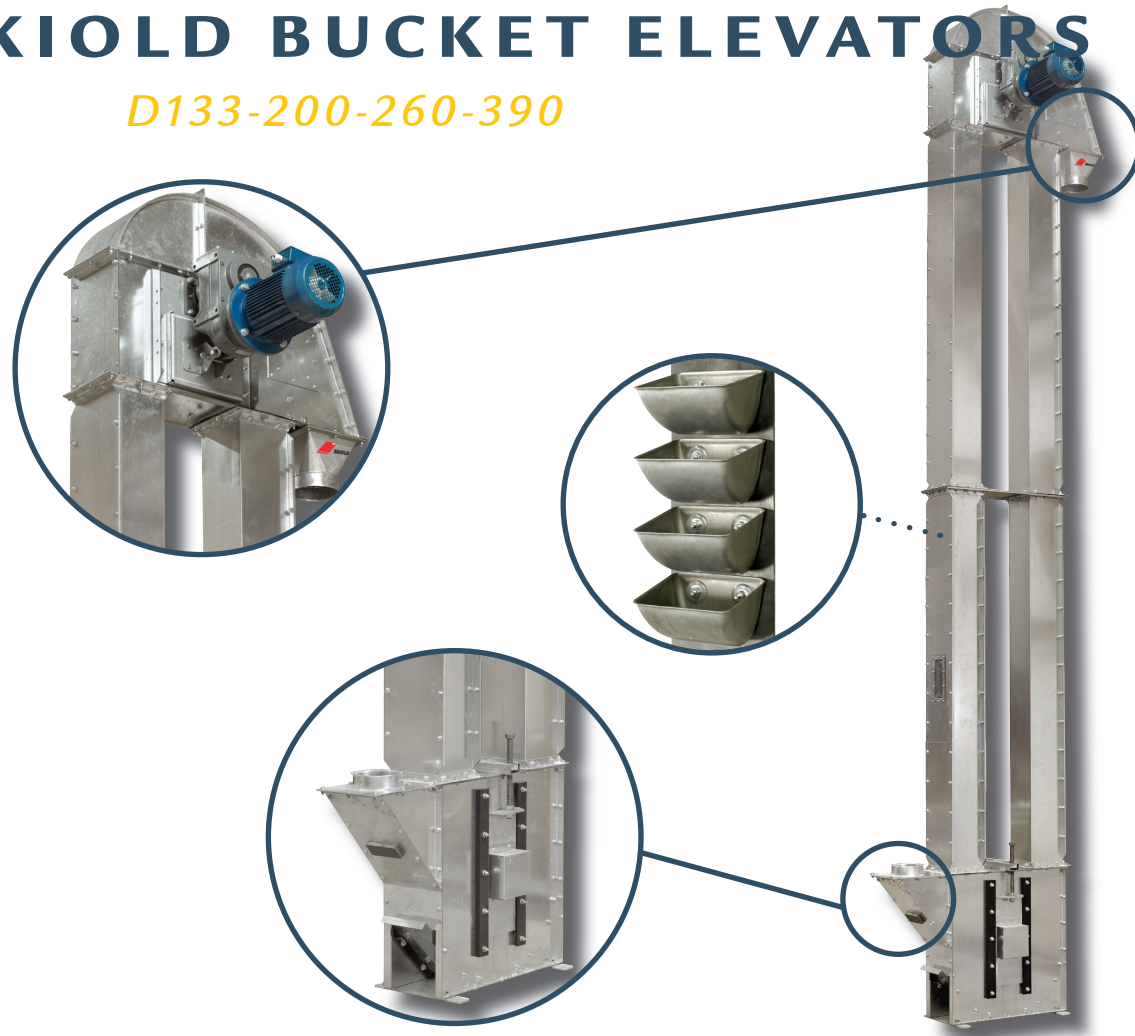

# SKIOLD BUCKET ELEVATORS

D133-200-260-390

## BUCKET ELEVATORS

The SKIOLD bucket elevators, type D, are designed for vertical conveying of grain, granulates and meal products – say ordinary small-grained crops and feed pellets with a maximum diameter of 16 mm and a maximum moisture content of 25% - yielding a capacity of up to 200 t/h in a maximum height of 40 m.

## MODULAR CONSTRUCTION

The construction of the elevators is based on modular sections comprising elevator foot, elevator head and extension sections equally equipped with bolt flanges for easy mounting. The extension sections come in lengths of 1.45, 1.95 and 2.45 m. The modular sections system, also comprising the accessory programme, is easily assembled and flexible securing the optimum design and solution for your specific task.

## INDUSTRIAL DESIGN

The SKIOLD bucket elevators are made in solid industrial design ensuring reliable operation for many hours a day. The elevator legging (trunking) is made from 1.5-2.0 mm

plate, head and base from 2.0-4.0 mm plate. All parts are as a minimum made from galvanized plate and a large number of key components have been hot dip galvanized.

## SHAFT MOUNTED GEARED MOTORS

The SKIOLD bucket elevators come with shaft mounted helical geared motors securing a minimum of maintenance. The gear motors can be either right or left fitted, again securing a high degree of flexibility.

## ACCESSORY

In addition, a profound accessory programme is available comprising:

- Misalignment control
- Dust aspiration
- Explosion relief
- Fittings for ladder
- Rain cap for motor (outdoor installation)
- Inlet regulations
- Various in- & outlet dimensions

SKIOLD MAKES THE DIFFERENCE!



- Capacity up to 200 tons/hour
- Vertical conveying of grain, granulates and meal
- Solid, galvanized construction
- Shaft mounted helical geared motor
- ATEX zone 22 approved

	A	B	C	D	E	F	F1	G	I	J	L
D133	133	133	267	605	633	2000	-	193	790	130	130
D200 I	200	200	295	750	735	2000	2500	260	1045	194	194
D200 II	200	200	295	750	735	2000	2500	260	1045	194	194
D260	260	228	380	1020	875	2000	2500	325	1370	310	256
D390	390	260	480	1160	1110	2000	2500	461	1550	300	386

Inlet and outlet can be supplied in the dimensions Ø150, 200, 250, 300 and Q16, 20, 24, 30

	Max. m <sup>3</sup> /hour	Bucket type	Buckets per meter	Belt width, mm	Motor kW	Max. height at max. capacity
D133	14 / 21	SPS80-80	9 / 13	100	1,1-2,2	35
D200 I	21 / 26 / 34	SPS100-90	8,5 / 10,5 / 14	120	2,2-4,0	40
D200 II	42 / 52 / 68	SPS 140-120	6,5 / 8 / 10,5	160	2,2-7,5	38
D260	94 / 120 / 145	SPS 200-150	5,5 / 7 / 8,5	215	5,5-15	36
D390	166 / 222 / 259	SPS 300-165A	4,5 / 6 / 7	330	11-30	41

Capacities in m<sup>3</sup>, grain. Capacity will vary for meal products. See detailed data sheet.

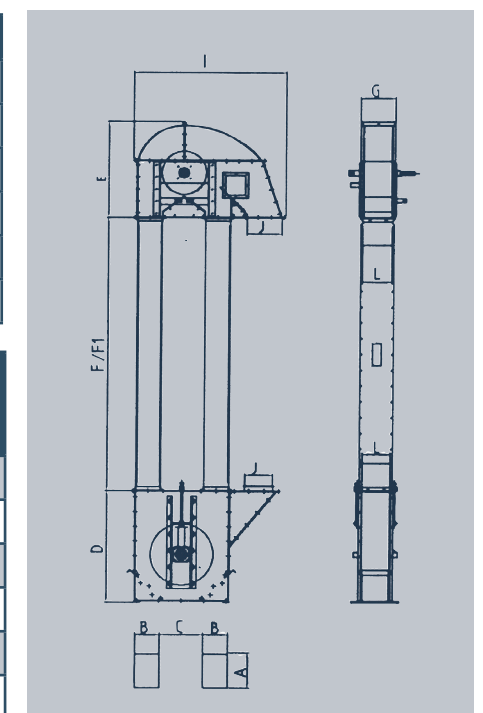

SKIOLD Reklame & Marketing - CB-2006.05.01 - All Rights Reserved.



SKIOLD A/S  
Kjeldgaardsvej · DK-9300 Sæby ·  
Tel: +45 99 89 88 87 · Fax: +45 99 89 88 77  
www.skiold.com · skiold@skiold.com

